

# Operating Instructions

## CS 3000

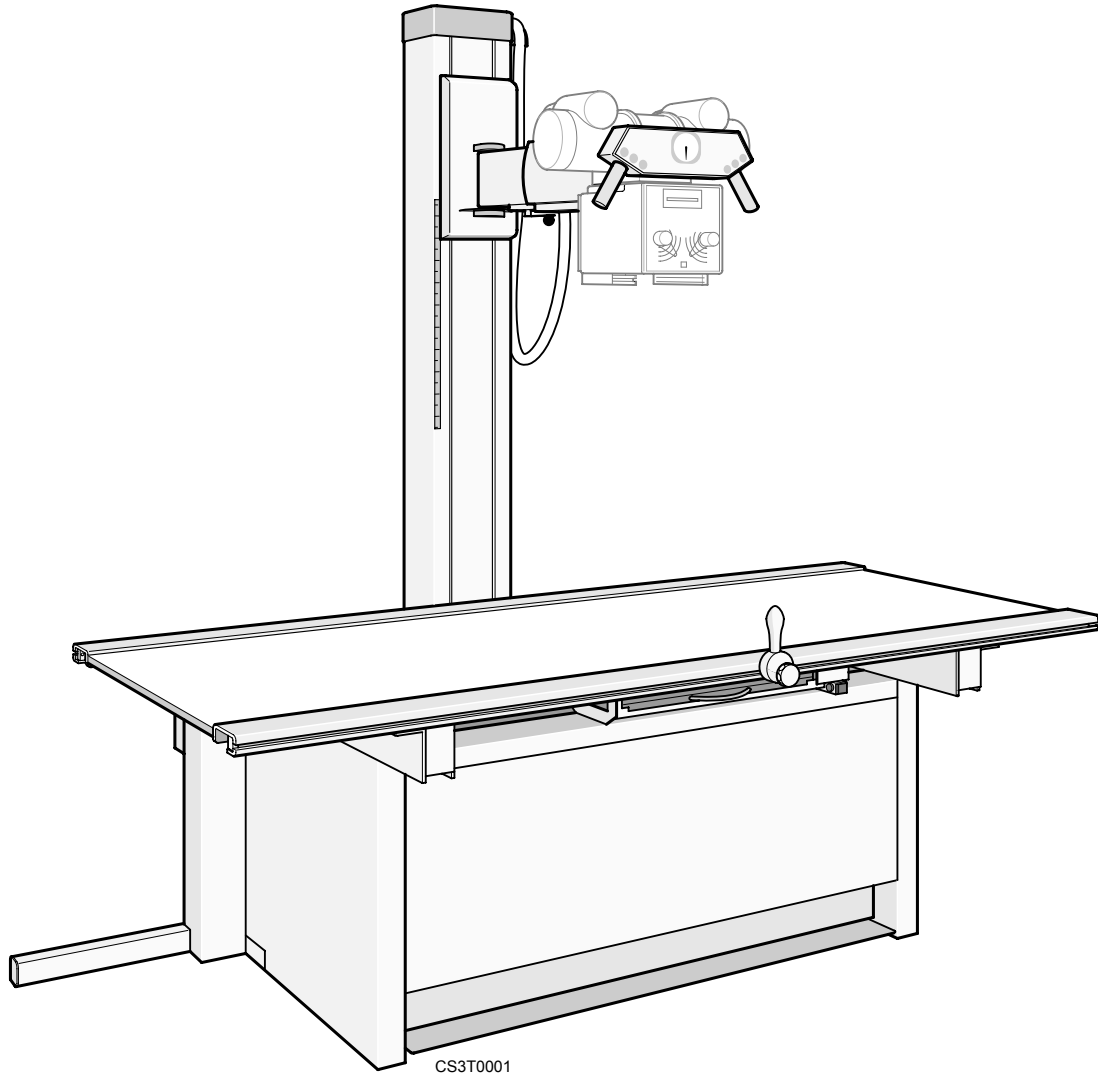

**CE** 1275

<b>Contents</b>	<b>Page</b>
<b>1 General safety instructions.....</b>	<b>4</b>
1.1 Warning statements and symbols.....	4
1.2 Abbreviations .....	4
1.3 Patient surrounding and exposure positions.....	5
1.3.1 Life time expectation.....	5
1.4 Warranty and liability .....	6
<b>2 Product safety .....</b>	<b>7</b>
2.1 Electrical safety.....	7
2.2 Cleaning the unit.....	7
2.3 EC Conformance .....	7
2.4 Column movements.....	7
2.5 Hotline.....	7
2.6 Pinch points .....	8
2.7 X-ray protection .....	8
2.8 Regulations in Germany: .....	8
2.9 The following notes should be observed: .....	9
2.10 Environmental Conditions for Operation.....	9
2.10.1 Installation with other units .....	9
2.11 General Regulation for safety acc. EN 60601-1-2-2002.....	9
<b>3 Technical data.....</b>	<b>13</b>
3.1 Electrical data .....	13
3.1.1 Weights.....	13
3.1.2 Environmental conditions.....	13
3.1.3 Packing and transport lanes .....	13
3.2 Floor space.....	14
3.3 AI-equivalent .....	14
3.4 Explosion protection .....	14
3.5 Classification per IEC 601-1: 1996 .....	15
3.6 Conformance according IEC 601-2-32: 1995 .....	15
3.7 Compatibility .....	15
3.8 Risk analysis.....	15
3.9 Disposal.....	15
<b>4 Product description .....</b>	<b>16</b>
4.1 Total view left hand version (Standard version).....	17
4.2 Operating Controls.....	18
4.3 Options .....	19
4.3.1 Tube support arm variants.....	19
4.3.2 Column – Bucky coupling .....	19
4.4 Operating functions and meaning of symbols.....	20
4.4.1 Operating with the control panel .....	20
4.4.2 Operating the table .....	21
4.4.3 Pivoting the tube support arm.....	22
4.5 Set up exposure position .....	23
4.5.1 Exposures with the patient laying down (e.g. Thorax, Abdomen, skeleton) .....	23
4.5.2 Exposures with a standing patient.....	26

CS 3000

---

<b>5</b>	<b>Original-Accessories .....</b>	<b>27</b>
5.1	Compression belt device .....	27
5.2	Head Clamp .....	28
5.3	Hip Clamp .....	28
5.4	Patient hand grip .....	29
5.5	Lateral cassette holder .....	29
5.6	Tübinger support system .....	29
5.7	Bucky P.....	29
5.8	Grid .....	29
<b>6</b>	<b>Maintenance .....</b>	<b>30</b>
6.1	Periodic Maintenance: .....	30
6.2	Operator's check list .....	30
6.2.1	Daily checks:.....	30
6.2.2	Weekly Checks: .....	30
6.3	Periodic Maintenance: .....	30
6.4	Cleaning:.....	31
6.5	Disinfection`s .....	31
<b>7</b>	<b>Council Directive 93/42 EEC concerning medical devices, Article 12.....</b>	<b>32</b>
<b>8</b>	<b>Name plate location .....</b>	<b>33</b>

### **Copyright**

The copyright of this manual remains at **PAUSCH technologies**.

This manual is only intended for the owner of this equipment and his staff.

This manual contains requirements and hints, which are not complete or in part to be

- Copied
- Distributed or
- Otherwise should be acquainted.

Violation may be subject to prosecute consequences.

All rights reserved.

CS 3000

---

## 1 General safety instructions

### 1.1 Warning statements and symbols

The following safety precautions in this Operating Instruction call attention to potentially dangerous conditions. These symbols for especially important tasks are used:



**Note!** Particular statements regarding the economical use of the CS 3000.



**Attention!** Particular statements regarding commandment or interdiction for damage protection

**Danger!** Particular statements regarding commandment or interdiction for personal- or voluminously material damage.



**Danger!**  
Radiation



**Danger!**  
If you use a disinfectant that can form an explosive gaseous mixture, they must have evaporated before the system is switched on again!!



**Danger!**  
Pinch Points



**Attention!**  
For connecting the Bucky please refer to the installation instruction of the manufacturer.



ESD – Electrostatic Discharge of Components.  
PC-Boards, pins and plugs which are marked with this label should not be touched with bare hands that means there should be no connection between these plugs without appropriate ESD-protection



The equipment is classified and marked according to the type of protection against electric shock as CLASS I Equipment and according to the degree of protection against electric shock as TYPE B Equipment.

### 1.2 Abbreviations

SID source image distance = FFA

CS 3000

---

### 1.3 Patient surrounding and exposure positions

The patient is laying on the table top of the CS3000. The column can be moved in longitudinal direction of the table and the tube support arm can be moved up and down in vertical direction. The table top is floating in longitudinal and lateral direction so that x-ray exposures can be made from head to the feet.

#### 1.3.1 Life time expectation

The life time expectation of the CS 3000 is calculated for 10 years. After that time the user can send the unit to the manufacturer for a general inspection and service at his own expense and than the CS 3000 can be operated and used for another 5 year period.

Proper use also means to pay attention to the operating manual as well as to follow up on inspections and maintenance schedules. The user is always responsible for maintaining regulations that apply for operation of the radiographic unit. Keep this operating manual for the CS 3000 always handy at location.



**Safety Note:**

Use only the CS 3000 in a safe and functional condition.

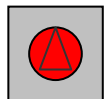

If there is any danger for patient or operator in an emergency situation and in connection with malfunctioning of the CS 3000 you must immediately press the red emergency off button in the room.

CS 3000

---

#### 1.4 Warranty and liability

Basically our „general sales and terms of delivery“ are valid. The user when signing the contract knows these. Warranty and liability claims by person- and material damage are excluded when one or more of the following causes can be conducted:

- Improper use of the CS 3000 and its components
- Improper mounting, take in operation, operation and service of the CS 3000 and its X-ray equipment
- Operating the CS 3000 under unsafe condition or improper installed safety guards or protection device
- Not observing the notes in the operating instructions regarding transportation, storage, assembly, initial start up, operating, maintenance and preparation time of the CS 3000
- Unauthorized constructional changes of the CS 3000
- Unauthorized changes to the e.g. drive controls: power, pressure and rpm
- Inadequate observation of machine parts, which are subject to wear
- Improper performed repair
- Disaster cases thru foreign bodies and higher authority.

Warranty: 12 Month  
Life time: 10 Years



#### **Safety Note § 14 MDD**

According § 14 MDD this product may only be erected, operated, applied and kept in condition in connection with the legal ordinance acc § 37 item 5. This product shall not be operated and used in case of any deficiencies that may endanger patients, user or third parties.

This product should not be operated or used in case of any defects that may cost harm to the patient, operator or third parties.

CS 3000

---

## 2 Product safety

### 2.1 Electrical safety

Only well trained service personal may remove covers and panels of this unit.

### 2.2 Cleaning the unit



**Attention!**

Switch of the unit prior to cleaning.  
No moisture may get into the unit.

### 2.3 EC Conformance

This radiological unit meets the general requirements according to the specifications of the EC Guideline 93/42 of the Council for Medical Products per Article 11, Section 5 and to the procedure listed in Appendix II.

**The CE - Mark applies only for the product without X-ray components.**

### 2.4 Column movements

To avoid shocks and damage to the unit always move the column by hand with a normal speed and not too hard against the mechanical end stops.



**Attention!**

If the vertical movement of the tube support arm sounds shaving or grinding do not operate the unit any further because one of the wire ropes could be broken. Please contact your service and avoid any kind of hard vibration and knocks.

### 2.5 Hotline

Additional information can be obtained by request from

Pausch technologies  
Hotline  
Postfach 28 60  
D-91056 Erlangen  
Phone +49 9131 999242  
Fax: +49 9131 9992-69  
E-mail: [service@pausch.de](mailto:service@pausch.de)

CS 3000

---

## 2.6 Pinch points



### **Danger!**

The following sketch indicates dangerous locations where patient or operator can be injured or pinched. Please pay attention that neither the patient nor yourself get pinched or hurt in this area.

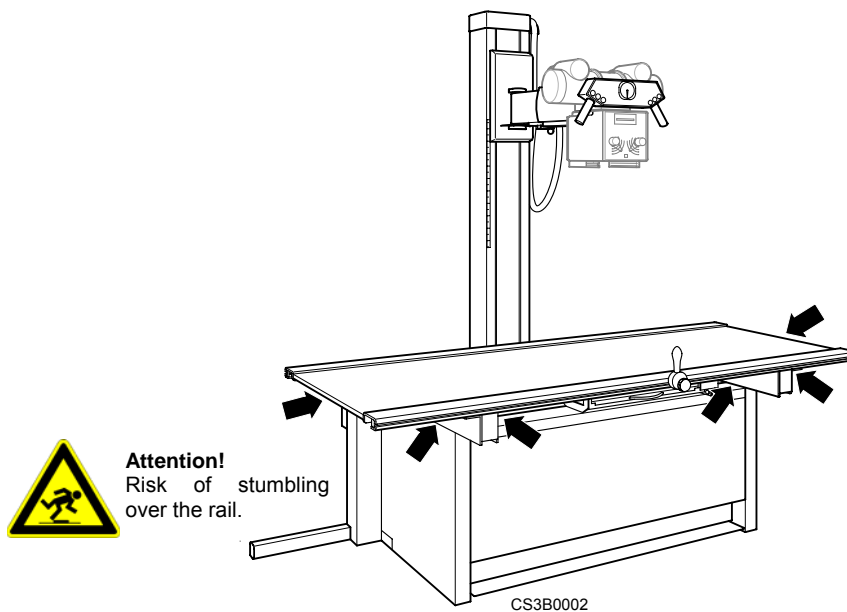

III. 1

## 2.7 X-ray protection



### **Danger X-Ray!**

In all countries outside the Federal Republic of Germany the corresponding national regulations must be met.

We recommend to maintain safety to operator, patient and third parties to follow up this rules in addition to the local and national regulations.

## 2.8 Regulations in Germany:

§ 16 RöV – constant test

Before start- up:

- Acceptance test
- Expert inspection
- Constant test (according the time intervals specified)

CS 3000

## 2.9 The following notes should be observed:

- Limit radiation field as small as possible
- Make sure to protect patient against radiation during examinations in the gonadal and / or crotch area.
- In the restricted area wear protective clothing during examinations.
- Keep maximal possible distance to the radiation source.
- No other persons are to be allowed in the restricted area.

## 2.10 Environmental Conditions for Operation

Ambient temperature range	10 °C to 40 °C
Relative humidity:	20 % to 80 %
Atmospheric pressure:	700 hPa to 1060 hPa

### 2.10.1 Installation with other units



#### Attention!

The CS 3000 should not be installed or operated in the direct nearness of other electronic units.

Should it be however necessary make sure that the CS 3000 is functioning properly.

## 2.11 General Regulation for safety acc. EN 60601-1-2-2002

Guidance and Manufacturer's Declaration - Electromagnetic Emissions		
The CS 3000 is intended for use in the electromagnetic environment specified below. The customer or the user of the CS 3000 should assure that it is used in such an environment.		
Emissions test	Compliance	Electromagnetic environment – guidance
RF-emissions Acc. CISPR 11	Classe B	The CS 3000 is suitable for use in all establishments, including domestic establishments and those directly connected to the public low-voltage power supply network that supplies buildings used for domestic purposes.
Harmonic emissions Acc. IEC 61000-3-2	Classe A	
Voltage fluctuations/ Flicker emissions Acc. IEC 61000-3-3	complies	

Table 201

CS 3000

<b>Guidance and Manufacturer's Declaration - Electromagnetic Emissions</b>			
The CS 3000 is intended for use in the electromagnetic environment specified below. The customer or the user of the CS 3000 should assure that it is used in such an environment.			
Immunity est	IEC 60601 Test level	Compliance level	Electromagnetic environment – guidance
Electrostatic Discharge (ESD) acc. IEC 61000-4-2	± 6 kV Contact  ± 8 kV Air	± 6 kV Contact  ± 8 kV Air	Floors should be wood, concrete or ceramic tile. If floors are covered with synthetic material, the relative humidity should be at least 30%.
Electrical fast transient/ bursts aac. IEC 61000-4-4	± 2 kV for Power supply lines  ± 1 kV for I/O lines (input/output)	± 2 kV for Power supply lines  ± 1 kV for I/O lines	Mains power quality should be that of a typical commercial or hospital environment.
Surges aac. IEC 61000-4-5	± 1 kV differential mode ± 2 kV common mode	± 1 kV differential mode ± 2 kV common mode	Mains power quality should be that of a typical commercial or hospital environment.
Voltage dips, short interruptions and voltage variations on power supply input lines acc. IEC 61000-4-11	< 5 % $U_T$ (> 95 % dip in $U_T$ ) for 0,5 cycle  40 % $U_T$ (60 % dip in $U_T$ ) for 5 cycles  70 % $U_T$ (30 % dip in $U_T$ ) for 25 cycles  < 5 % $U_T$ (> 95 % dip in $U_T$ ) for 5 s	< 5 % $U_T$ (> 95 % dip in $U_T$ ) for 0,5 cycle  40 % $U_T$ (60 % dip in $U_T$ ) for 5 cycles  70 % $U_T$ (30 % dip in $U_T$ ) for 25 cycles  < 5 % $U_T$ (> 95 % dip in $U_T$ ) for 5 s	Mains power quality should be that of a typical commercial or hospital environment. If the user of the CS 3000 requires continued operation during power mains interruption, it is recommended that the CS 3000 be powered from an interruptible power supply or a battery.
Power frequency (50/60 Hz) Magnetic field acc. IEC 61000-4-8	3 A/m	Not applicable	Power frequency magnetic fields should be at levels characteristic of a typical location in a typical commercial or hospital environment
NOTE $U_T$ is the a.c. mains voltage prior to application of the test level.			

Table 202

CS 3000

<b>Guidance and Manufacturer's Declaration - Electromagnetic Emissions</b>			
The CS 3000 is intended for use in the electromagnetic environment specified below. The customer or the user of the CS 3000 should assure that it is used in such an environment.			
Immunity test	IEC 60601 Test level	Compliance level	Electromagnetic environment – guidance
			Portable and mobile RF communications equipment should be used no closer to any part of the CS 3000, including cables, than the recommended separation distance calculated from the equation applicable to the frequency of the transmitter. <b>Recommended separation distance</b>
Conducted RF acc. IEC 61000-4-6	3 V <sub>eff</sub> 150 kHz 80 MHz	3 V <sub>eff</sub>	$d = 1,2\sqrt{P}$
Radiated RF acc. IEC 61000-4-3	3 V/m 80 MHz to 2,5 GHz	3 V/m	$d = 1,2\sqrt{P}$ 80 MHz to 800 MHz
			$d = 2,3\sqrt{P}$ 800 MHz to 2,5 GHz
			Where P is the maximum output power rating of the transmitter in watts (W) according to the transmitter manufacturer and d is the recommended separation distance in meters (m).  Field strengths from fixed RF transmitters, as determined by an electromagnetic site survey <sup>a</sup> should be less than the compliance level in each frequency range <sup>b</sup> . Interference may occur in the vicinity of equipment marked with the following symbol:  
NOTE 1	At 80 MHz and 800 MHz, the higher frequency range applies.		
NPTE 2	These guidelines may not apply in all situations. Electromagnetic propagation is affected by absorption and reflection from structures, objects and people.		
a	Field strengths from fixed transmitters, such as base stations for radio (cellular/cordless) telephones and land mobile radios, amateur radio, AM and FM radio broadcast and TV broadcast cannot be predicted theoretically with accuracy. To access the electromagnetic environment due to fixed RF transmitters, an electromagnetic site survey should be considered. If the measured field strength in the location in which the CS 3000 is used exceeds the applicable RF compliance level above, the CS 3000 should be observed to verify normal operation. If abnormal performance is observed, additional measures may be necessary, such as reorienting or relocation the CS 3000.		
b	Over the frequency range 150 kHz to 80 MHz, field strengths should be less than [V <sub>1</sub> ] V/m.		

Table 203

CS 3000

<b>Recommended separation distance between Portable and mobile RF communications equipment and the CS 3000</b>			
The CS 3000 is intended for use in an electromagnetic environment in which radiated RF disturbances are controlled. The customer or user of the CS 3000 can help prevent electromagnetic interference by maintaining a minimum distance between portable and mobile RF communications equipment (transmitter) and the CS 3000 as recommended below, according to the maximum output power of the communication equipment.			
Rated maximum output power of transmitter  W	Separation distance according to frequency of transmitter m		
	150 kHz to 80 MHz  $d = 1,2\sqrt{P}$	80 MHz to 800 MHz  $d = 1,2\sqrt{P}$	800 MHz to 2,5 GHz  $d = 2,3\sqrt{P}$
0,01	0,12	0,12	0,23
0,1	0,38	0,38	0,73
1	1,2	1,2	2,3
10	3,8	3,8	7,3
100	12	12	23
For transmitters rated at a maximum output power not listed above, the recommended separation distance $d$ in meters (m) can be estimated using the equation applicable to the frequency of the transmitter, where $P$ is the maximum output power rating of the transmitter in watts (W) according to the transmitter manufacturer.			
NOTE 1 To calculate the recommended separation distance of transmitters in the frequency range at 80 MHz to 2,5 GHz an additional factor of 10/3 was used, to limit the possibility for the patient area that unintentional brought in mobile or portable communication equipment can cause any disturbance.			
NOTE 2 These guidelines may not apply in all situations. Electromagnetic propagation is affected by absorption and reflection from structures, objects and people.			

Table 204

CS 3000

### 3 Technical data

#### 3.1 Electrical data

Rated Voltage, Frequency	115/230 V, 60/50 Hz
Rated current	2/1 A

#### 3.1.1 Weights

Table	187 kg
Column	120 kg
Tube support arm fixed	20 kg
Tube support arm pivoting	25 kg
Tube support arm pivoting and telescopic function	25 kg
Total weight of tube and collimator	40 kg

#### 3.1.2 Environmental conditions

	Operation	Shipping	Storage
Ambient temperature range:	+10°C to +40°C	-20°C to +60°C	-20°C to +60°C
Relative humidity:	20 % to 70 %	10 % to 90 %	10 % to 90 %
Atmospheric pressure:	700 hPa to 1060 hPa	500 hPa to 1060 hPa	500 hPa to 1060 hPa

#### 3.1.3 Packing and transport lanes

Palette Table	Length 1,60 m	Width 0,75 m	Weight 217 kg
Card box table top short	Length 2,10 m	Width 0,91 m	
Card box table top long	Length 2,30 m	Width 0,91 m	
Palette Column	Length 2,41 m	width 0,76 m	Weight 163 kg
Heaviest single part	187 kg		
Min. door width	0,90 m		

CS 3000

---

### 3.2 Floor space

#### Floor space required

The unit is designed for stationary operation. The floor space requires dimensions of approx. 330 cm by 152 cm. In addition a minimum spacing of 20 cm must be maintained between the unit and wall.

#### Room height

The height of the column is 228 cm. However the room height for installing the unit should be at least 245 cm. The table top of the unit has a working height of 75cm above the floor.

#### Electrical data's

The system is equipped for single-phase alternating current with fixed installation. According to the order it can be shipped in two versions. The unit is prepared for solid installation with an all poled separation from power (IEC 601, Chap. 57.1) Without transformer; the system corresponds to nominal ratings as follows:

Rated Voltage:	115/230 V AC
Rated Current:	2/1 A
Rated frequency:	50/60 Hz
Power consumption:	230 VA

#### Mains

The mains connection requires a 30 mA circuit breaker to be installed at location by the customer. The electrical installation must meet the relevant legislation, e.g. VDE 0107, In all other countries, the provisions of the applicable local laws and regulations have priority.

### 3.3 Al-equivalent

The aluminum equivalent value for the table top is  $\leq 0,7$  mm.

According to:

DIN EN 60601-1-3 with 100 kV and HWS 3,7 mm Al and

FDA 21 CFR § 1020.30 (n) with 100 kV and HWS 2,7 mm Al.

### 3.4 Explosion protection



#### Danger!

This unit should not be operated in explosive rooms.

If you use a disinfectant that can form an explosive gaseous mixture, they must have evaporated before the system is switched on again!!

CS 3000

---

### 3.5 Classification per IEC 601-1: 1996



The equipment is classified and marked according to the type of protection against electric shock as CLASS I Equipment and according to the degree of protection against electric shock as TYPE B Equipment.

### 3.6 Conformance according IEC 601-2-32: 1995

This unit Elevator 2 fulfills the requirements of the IEC 601-2-32.

### 3.7 Compatibility

The CS 3000 in its versions can be adapted with all combinations of tubes and collimators of all leading manufacturers. The tube/collimator combination should not have more than 40kg. At the moment the following tubes can be used.

- Siemens
- Philips
- Shimadzu

The CS 3000 can be combined with any brand of wall stands for exposures on a standing patient.

### 3.8 Risk analysis

Description of the remaining risk according to the risk management to medical devices regulation DIN EN ISO 14971:2003.

According to the conducted risk analysis this product is classified to be safe whereby it cannot be excluded, that a hitherto unknown remaining risk anymore can exist

### 3.9 Disposal

This product is built to the latest standard for environment protection.

Gather information from the authorities before placing the system out of operation about all applicable disposal regulations.

Care about proper environmental utilization!

CS 3000

---

## 4 Product description

### Brief description

The CS 3000 is an x-ray column solution for x-ray diagnostic from head to foot. It makes it possible to do examinations of the skull, thorax, pelvis and extremities on a lying and in connection with a Bucky wall stand on a standing patient.

The special installation- service- and user-friendly design guarantees always an economical use.

The equipment system is comprised of a patient table with a floating table top and the Bucky unit and a guided column stand for the x-ray tube, collimator and control handle. The stabile, vibration-free table base and the rail stand assembly for the column comprise a single unit.

Basically there are two versions of the x-ray unit CS 3000:

1. The left hand version (Standard version)
2. The right hand version (Special version)

The unit shown in Ill. 2 is the left hand version (Standard version) of the CS 3000, easy to notice on the on the guide rail on the back of the table on the left hand floor side for the column.

The large-area, 220 cm-long table top (optional 200 cm long) is float-mounted, can be moved manually and is electromagnetically braked. The ergonomically mounted foot switch near the floor and alongside of the table base allows that the locks (solenoids) of the electromagnetically locked table top can be released. The construction of the table is designed for a max patient load of 450 kg. The wide moving range of the table top is 60 cm to the left, 50 cm to the right and lateral  $\pm 12$  cm) and its easy movement permit a quick, effortless positioning of the patient.

The table top has a smooth T-slot profile rails on the side which can accept accessories. The scratch resistance surface (Resopal) and the covered, smooth rails make the table top especially convenient for the patient and easy to care for.

The adjustable Buck – suitable for installation of adjustable Buckys of all leading manufacturers- can be moved manually in longitudinal direction under the table top and is electromagnetically locked in place. The smallest possible film skin distance of 70 mm makes excellent geometrical exposures conditions. The table top, which is only minimally radiation absorbent (Al-attenuation equivalency value under 0,7 mm) has only a minimal effect on the dose. The Bucky can be unlocked by pushing the button on the Bucky carriage.

With a mechanical coupling the Bucky will automatically be connected to the column in the Bucky travel range.

The column with the tube support arm and the x-ray tube unit is guided in a rail assembly, parallel to the table longitudinal axis.

The x-ray tube unit with collimator and control panel for the column is mounted to a pivoting tube support arm on the vertical carriage. The vertical carriage can be moved vertical up and down and rotated around its lateral axis. These movements will allow that the beam axis can be adjusted and set in vertical, horizontal and oblique direction. Each position is electromagnetically locked in place.

The x-ray tube is normally mounted with trunions according DIN 6836 shape C. The max. weight of the x-ray tube unit with collimator should not have more than 40 kg (88 lbs).

CS 3000

#### 4.1 Total view left hand version (Standard version)

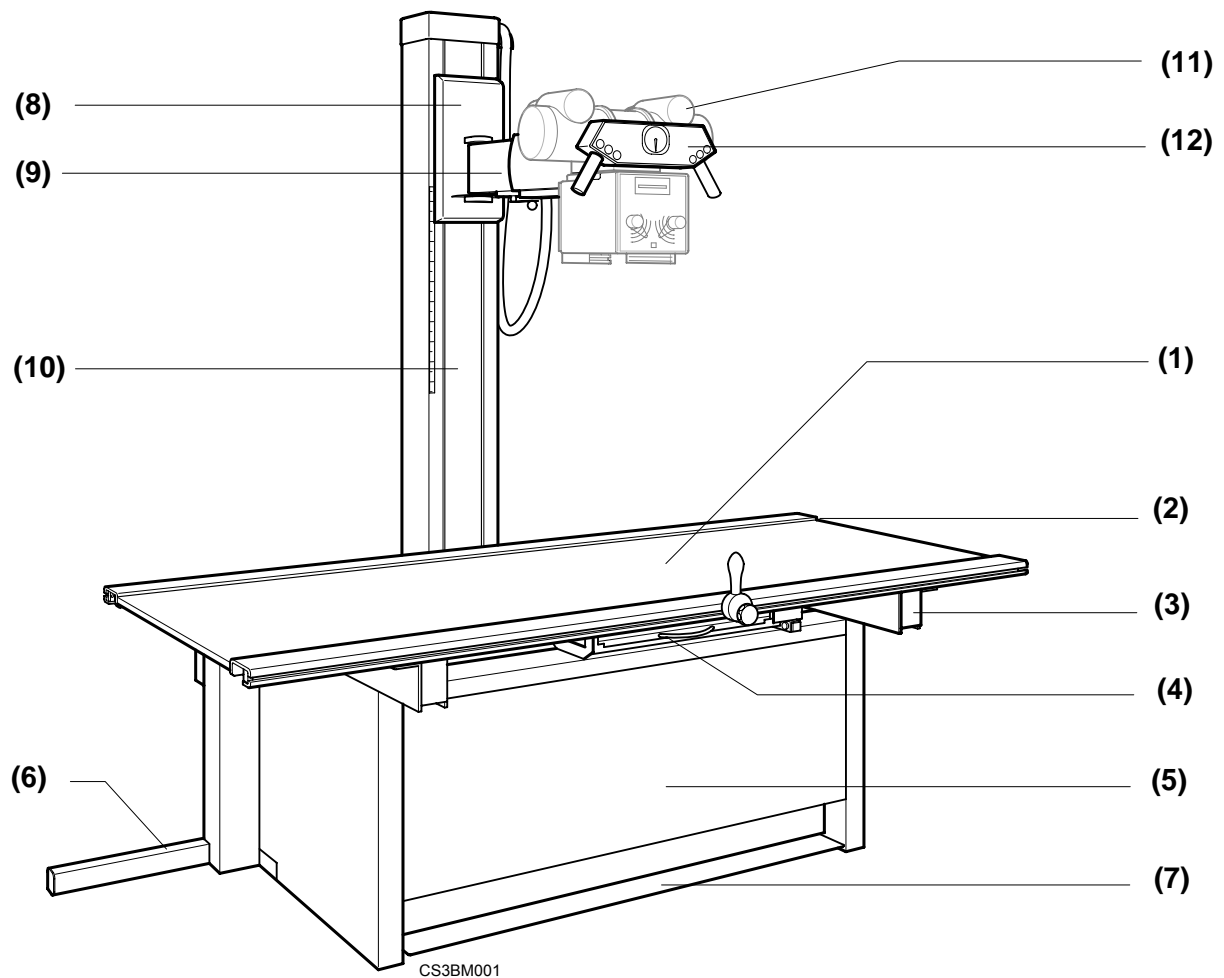

III. 2

- (1) Table top floating, moved manually, scratch-resistant
- (2) Profile rail, covered, smooth, for attachment of accessories
- (3) Table upper frame
- (4) Bucky moveable
- (5) Table base
- (6) Rail assembly for column stand left hand version (Standard version)
- (7) Foot switch
- (8) Vertical carriage
- (9) Tube support (see chapter 4.3 Options)
- (10) Column
- (11) X-ray tube
- (12) Control handle with protractor

CS 3000

## 4.2 Operating Controls

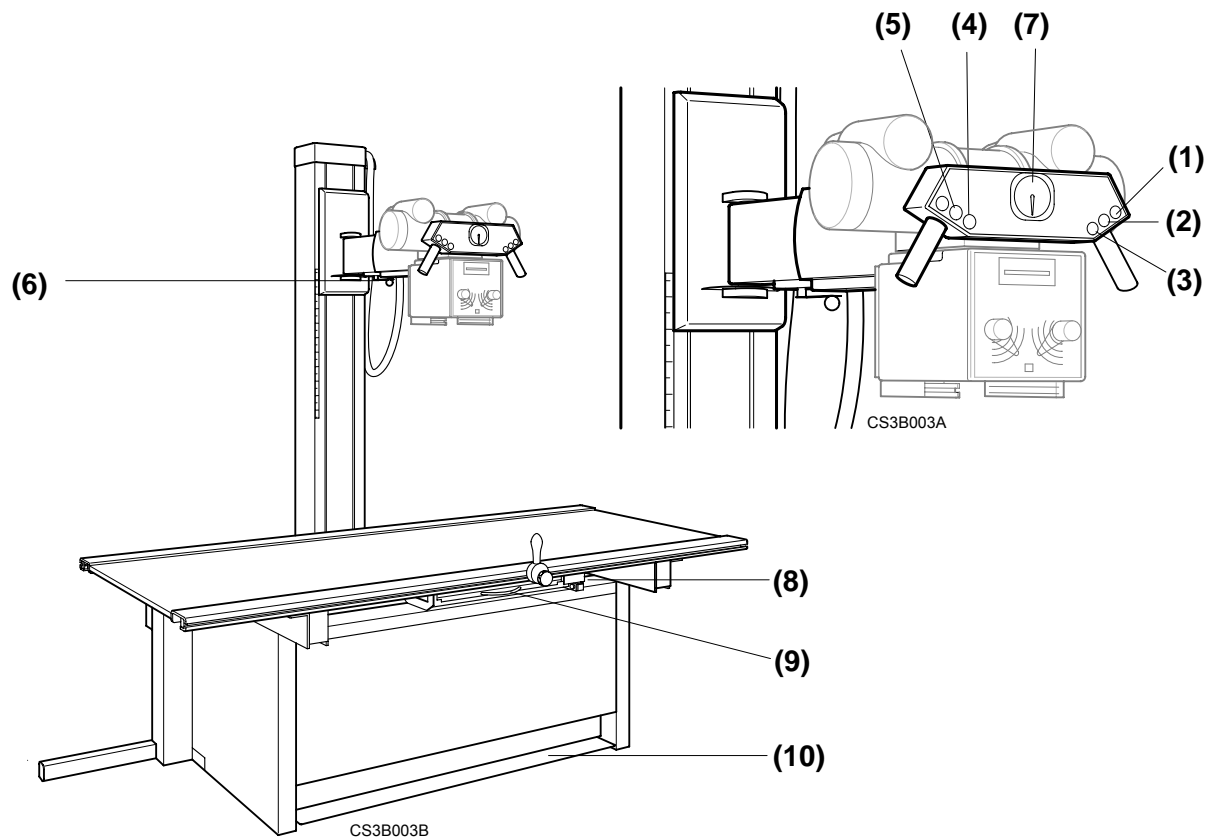

III. 3

- (1) Button for longitudinal movement of the column
- (13) Button for the vertical movement of the tube support arm
- (14) Button for both longitudinal and vertical motion of the column
- (15) Button for tube rotation
- (16) Button for the lateral movement of the tube (Option)
- (17) Unlocking lever for pivoting the tube support arm (Option)
- (18) Protector
- (19) Button for the Bucky
- (20) Handle for the cassette tray
- (21) Foot switch for longitudinal and lateral movement of the table top

CS 3000

---

## 4.3 Options

### 4.3.1 Tube support arm variants

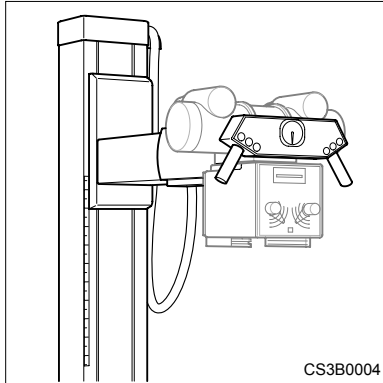

#### Variant 1

Fixed tube support arm:  
Fixed tube support arm for O.T. exposures and exposures with the wall stand.

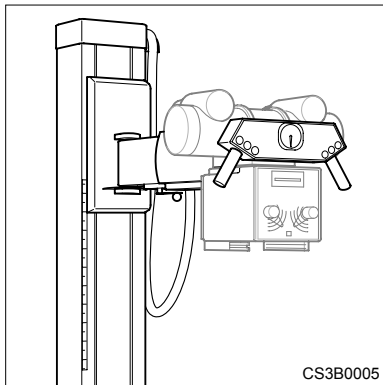

#### Variant 2

Pivoting tube support arm  
Support arm with pivoting function for lateral exposures

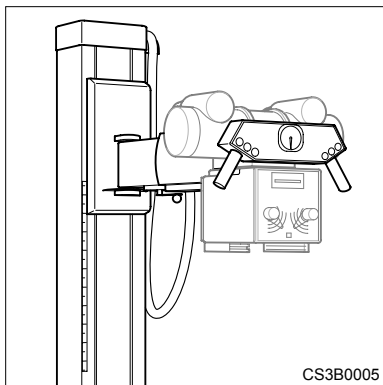

#### Variant 3

Telescopic tube support arm  
Support arm with telescopic function (in lateral direction) and pivoting function for lateral exposures.

### 4.3.2 Column – Bucky coupling

An automatic coupling is connecting the Bucky in its entire travel range to the column and is automatically centering the tube to the cassette size.

CS 3000

---

## 4.4 Operating functions and meaning of symbols

### 4.4.1 Operating with the control panel



#### Button 1

To release the brake for the longitudinal motion of the column and the x-ray tube. Releasing the button will hold the column in its new position.

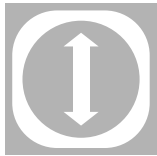

#### Button 2

To release the brake for the vertical movement of the tube support arm. Releasing the button again will lock the tube in its new position.



#### Button 3

To release both brakes for the longitudinal and vertical movement. Releasing the button will lock the tube in its new position.



#### Button 4

To release the brake for the tube rotation. Releasing the button will lock the tube in its angulated position.

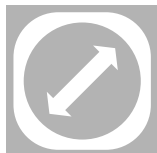

#### Button 5

To release the brake for the lateral movement of the x-ray tube. Releasing the button will lock the tube in its new position (only available with tube support arm variant 3, see chapter 4.3 *Options*).

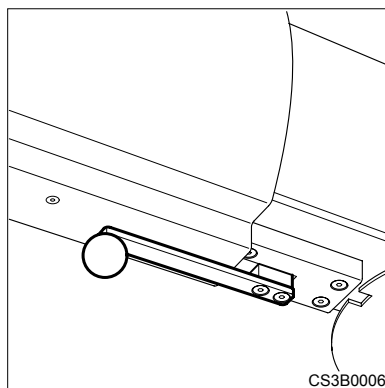

#### Unlocking lever for pivoting the tube support arm 6

To release the catch for pivoting the tube arm. The x-ray tube can be rotated to  $\pm 90^\circ$  and  $0^\circ$  (only with tube support arm variant 2 and 3, see Chapter 4.3 *Options*).

CS 3000

---

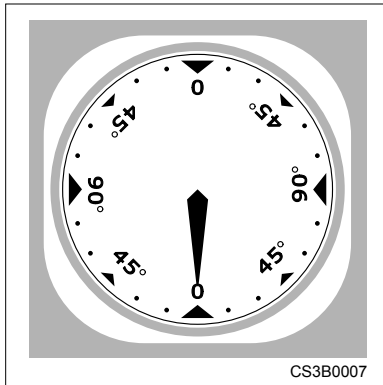

**Protactor 7**

Is showing the angle measurement of the tube support arm.

**4.4.2 Operating the table**

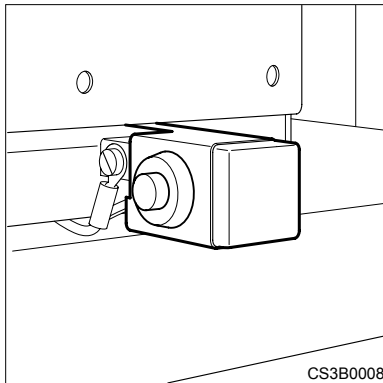

**Button 8**

To move the Bucky carriage.

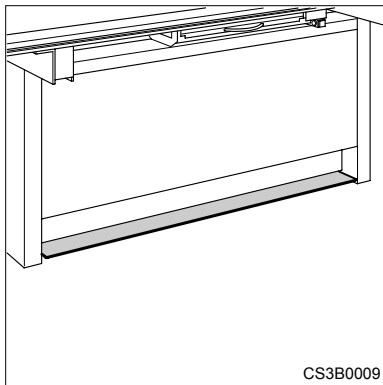

**Foot switch 10**

To release the brakes for the table top. Releasing the foot switch will lock the table top in its new working position.

CS 3000

---

#### 4.4.3 Pivoting the tube support arm

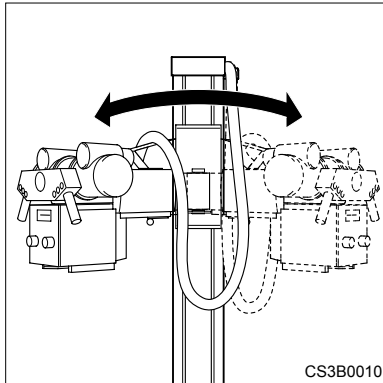

Releasing the lever the tube support arm and the x-ray tube can be moved by hand to the left or right 90°. Mechanical detents will hold the tube at 0° and ±90° (only possible with tube support variant 2 and 3, see chapter 4.3 *Options*).

CS 3000

## 4.5 Set up exposure position

### 4.5.1 Exposures with the patient laying down (e.g. Thorax, Abdomen, skeleton)

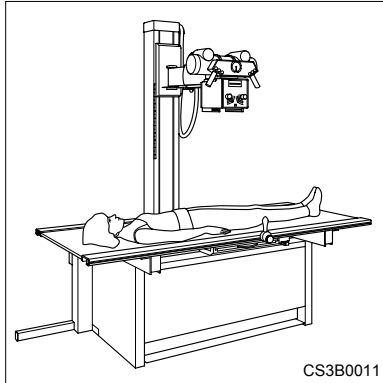

**Position the patient on the table top.**



**Note!**

Before putting the patient on the table top make sure that the column and x-ray tube is out of the way so no one get hurt!!

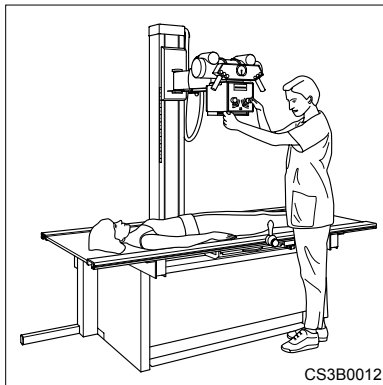

**Positioning of the x-ray tube**

The Bucky will automatically move along with the column if both parts are coupled to each other.



**Note!**

The Bucky must be centered separately if not coupled to the column.

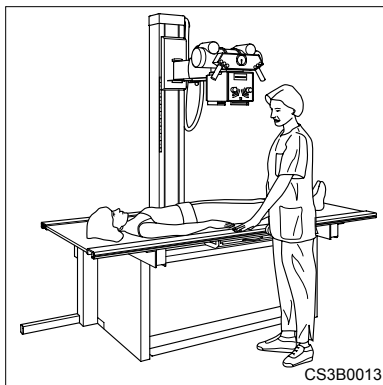

**Centering the exposure object**

Move the patient into exposure position by moving the entire table top.

To move the table top step on the foot switch **10**. Release the foot switch in the desired position to lock the table top in place.

CS 3000

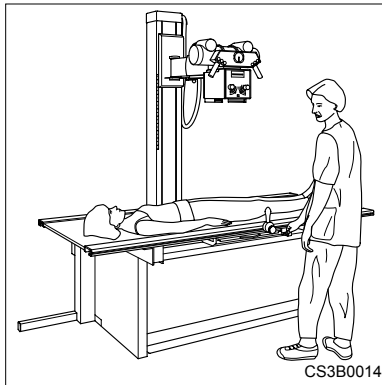

### Collimating the x-ray field

Collimate the x-ray field (light field of the collimator) to the cassette size used. (c.f. operating instructions of the collimator).



### Attention!

- Insert cassette and set the proper SID.
- Set the exposure data's at the control panel of the generator
- Check readiness for exposure.
- Command patient to hold your breath!
- Trigger exposure.



### Note!

Do not forget radiation protective measures for the patient, lead-rubber apron (gonad protector, ect.)!

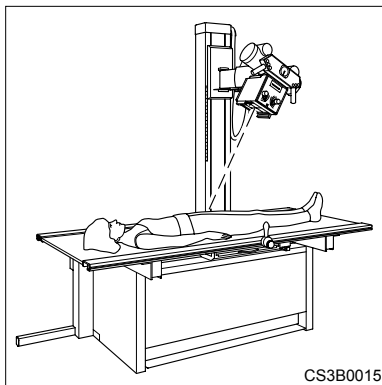

### Oblique exposures

Move the column out of the automatic coupling range of the Bucky. Position the Bucky under the patient. Now use the light beam of the collimator to center the x-ray tube (ungulate) to the center of the Bucky (cassette).



### Note!

Make sure when positioning the tube to the Buck that the column will not couple to the Bucky.

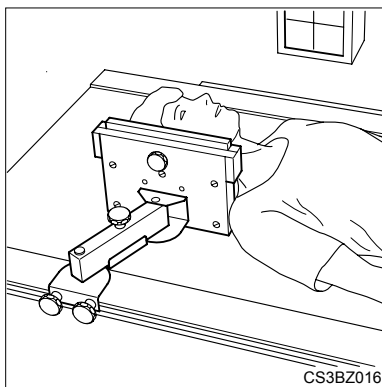

### Lateral exposures

For lateral exposures with the lateral cassette holder (see also page 29 *Lateral cassette holder*), unlock the tube support arm and rotate the arm around 90° and rotate the x-ray tube around 90° (protactor!). All other settings as described. Only with tube support arm variant 2 and 3 possible, see Chapter 4.3 *Options*.

CS 3000

---

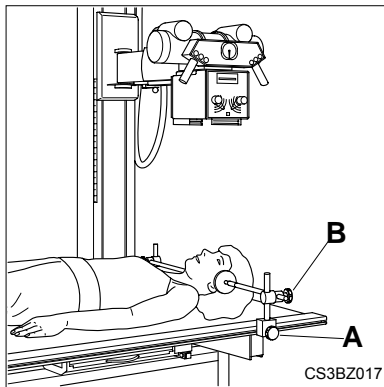

**Head Clamp**    Ordering-No.: 0920 0022a/b

The head clamp is used in connection with the adapter part 0920 0040 to secure the patient's head in place.

The head clamps are slid into the side rails of the table top and can be locked in place in any position using hand screw **A**.

Hand screw **A**:            Fix the holder to table top in the profile rails

Hand screw **B**:            Position patient's head.

CS 3000

#### 4.5.2 Exposures with a standing patient

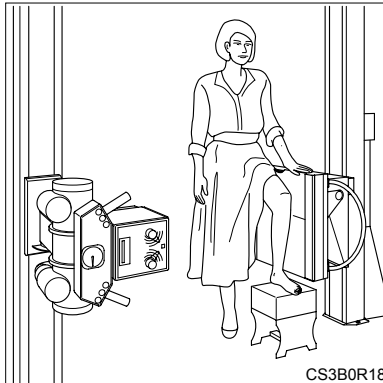

##### Position the patient in front of the wall stand

Move the Bucky of the wall stand into exposure position.

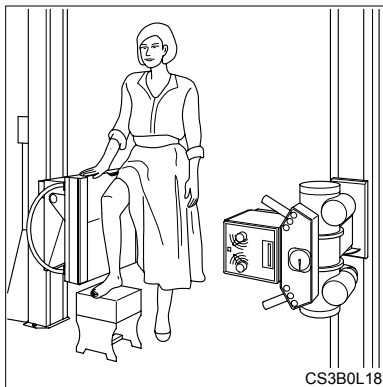

Rotate x-ray tube to face the wall Bucky

##### Wall stand is on the left side:

Move the table top all the way to the right hand side and move the column all the way to the left. Rotate the x-ray tube to the  $-90^\circ$  position.

##### Wall stand is on the right side:

Move the table top all the way to the left hand side and move the column all the way to the right. Rotate the x-ray tube to the  $+90^\circ$  position.

Center the tube to the wall Bucky.

##### Collimating the x-ray field

Collimate the x-ray field (light field of the collimator) to the cassette size used. (c.f. operating instructions of the collimator)



##### Attention!

- Insert cassette and set the proper SID.
- Set the exposure data's at the control panel of the generator
- Check readiness for exposure.
- Command patient to hold your breath!
- Trigger exposure.



##### Note!

Do not forget radiation protective measures for the patient, lead-rubber apron (gonad protector, ect.)!

CS 3000

## 5 Original-Accessories

### 5.1 Compression belt device



#### Attention!

Use only original accessories.

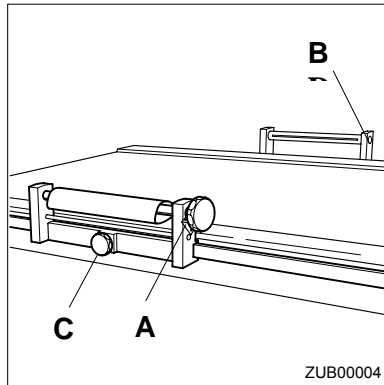

Ordering-No.: 0902 0030

#### Compression Belt Device

The compression belt device is used to fix the patient in place and decrease the body mass to limit scattered radiation for better image exposures.

**Mounting:** Slide in the compression belt holder **B** onto the rear table top side rail and fasten in place using hand screw **C** in working position.

Insert compression device assembly **A** into the front rail opposite belt holder **B** and fasten in place using knob screw **C**.

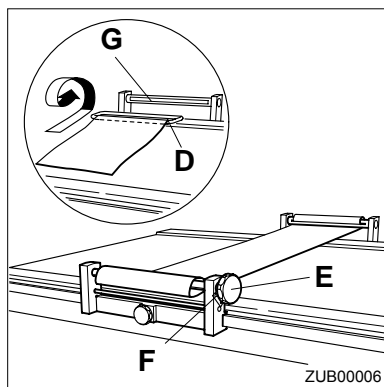

Press the ratchet lever **F**. Unroll the belt and stretch it across the patient

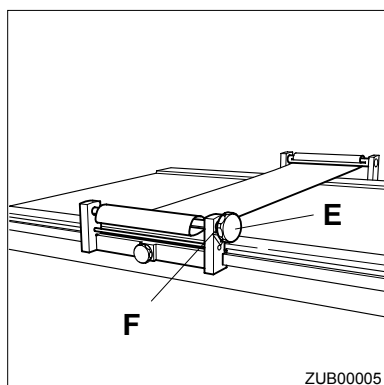

Wrap the belt around the metal rod of the holder **B**. Insert the metal bar **D** on the end of the compression belt into the slot **G**

Use tightening knob **E** to tighten the compression belt.

CS 3000

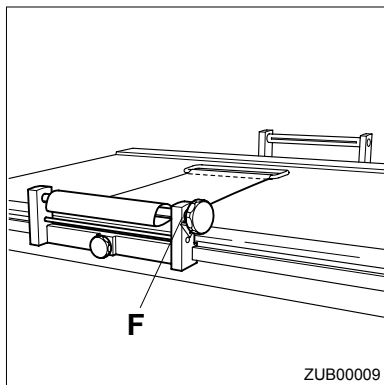

**To release the belt**

Press ratchet lever **F**, unroll the compression belt and remove it.

**5.2 Head Clamp**

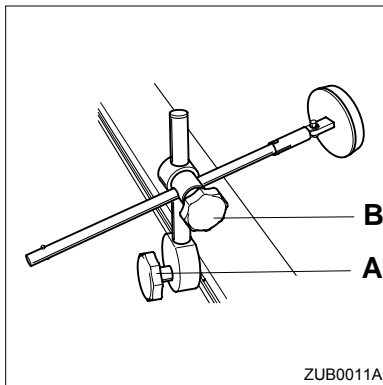

**Clamp** Ordering-No.: 0920 0022a/b

The head clamp is used in connection with the adapter part 0920 0040 to secure the patient's head in place.

The head clamps are slid into the side rails of the table top and can be locked in place in any position using hand screw **A**.

Hand screw **A**: Fix the holder to table top in the profile rails.

Hand screw **B**: Position patient's head.

**5.3 Hip Clamp**

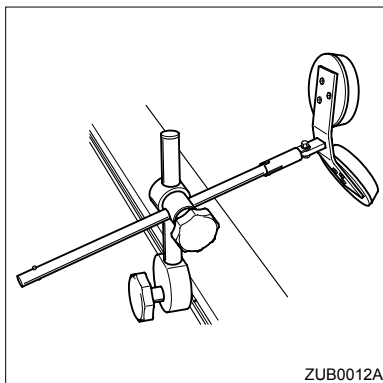

**Clamp** Ordering-No.: 0920 0018

The hip clamp is used in connection with the holder 0920 0040 to fix the patients hip in place.

The hip clamps are slid into the side rails of the table top and can be locked in place in any position using hand screw **A**.

Hand screw **A** Fix the holder to table top in profile rail.

Hand screw **B** Position patient's hip.

CS 3000

#### 5.4 Patient hand grip

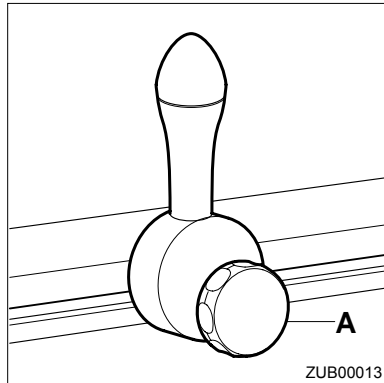

Ordering-No.: 0903 0000

The patient handgrip serves as a means of locating the patient's hand away from the table edges and to give the patient a feeling of security. However, they are not intended to support the weight of the patient. The handles are slid into the side rails of the table top. They can be locked in place in any position using hand screw A.

#### 5.5 Lateral cassette holder

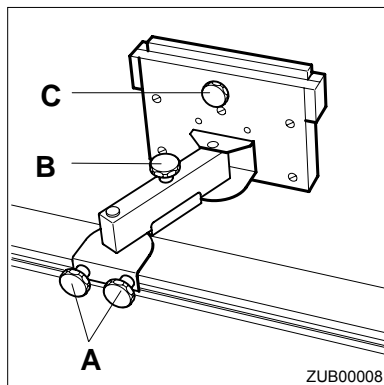

Ordering-No.: 0930 0000

Use the lateral cassette holder to take lateral views of the patient. The cassette holder slides onto the front side rail of the table top. Rotate the tube arm 90° and angle the x-ray tube to point in lateral direction.

Hand screws A: Lock the holder to table rail.

Hand screw B: Swings the holder to exposure position.

Hand screw C: Loosens the cassette clamp and locks the cassette in place.

#### 5.6 Tübinger support system

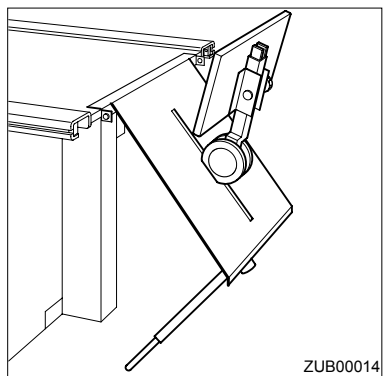

Ordering-No.: 0940 0020

The Tübinger support system makes it possible to do standardized exposures of one or both Femoropatellarjoints at the same time.

#### 5.7 Bucky P

Ordering-No.: 7163 0022

#### 5.8 Grid

Ordering -No.: 0008 0267a

CS 3000

---

## 6 Maintenance



### Note!

Like any other technical equipment, this radiographic unit and its accessories requires a regular maintenance and care to ensure the operating reliability of the unit..

Please call for service if you notice unusual noises or any defect is on the unit.

### 6.1 Periodic Maintenance:

To maintain trouble-free operation of the CS 3000 as well as to ensure safety for patients and operating personal, technical maintenance should be performed by customer service in 12- month intervals.

See chapter "*Technical Maintenance*" in the mounting instructions.



### Note!

The live time expectation of the CS 3000 is calculated for 10 years. After that time the user can send the unit to the manufacturer for a general inspection and service at his own expense and than the CS 3000 can be operated and used for another 5 year period.

### 6.2 Operator's check list

The user must check the radiographic unit and accessories for deficiencies as described below.

If there is functional or other deficiencies from normal operating behavior switch the unit off immediately and contact customer service.

The unit may be put back into operation only after all deficiencies have been corrected.

#### 6.2.1 Daily checks:

Operating controls, markings and warning signs.

#### 6.2.2 Weekly Checks:

Check all cables and connections for damage or broken cables.

### 6.3 Periodic Maintenance:

To maintain trouble-free operation of the CS 3000 as well as to ensure safety for patients and operating personal, technical maintenance should be performed by customer service in 12- month intervals.

See chapter "*Technical Maintenance*" in the mounting instructions.



### Caution!

If there is a failure of parts that may affect the safety of the unit, original spare parts must be used..

We also recommend that written verification of the type and extent of work performed be requested from the person performing the work, and if applicable, including changes to nominal data or of the operating range, and with date, company name and signature.

CS 3000

---

#### 6.4 Cleaning:



##### **Caution!**

Switch the system off prior to cleaning it.

The plastic surfaces may be cleaned only with soapy water because other agents (e.g. containing alcohol) can dull the finish and cause it to become brittle.

No caustic, solvent or abrasive cleaners or polishes may be used.

Water or any other liquid may not get into the inside of the unit because this can cause short-circuits in the electrical installation and to avoid corrosion of parts.

Painted parts and aluminum surfaces may only be wiped down with a damp cloth and wiped dry with a cotton cloth.

Chromed parts may only be wiped down with a dry cotton cloth. Die verchromten Teile dürfen nur mit einem trockenen Wolltuch abgerieben werden.

#### 6.5 Disinfection`s

Clean all surfaces on a regular basis.



##### **Note!**

Only those disinfection's methods that correspond to applicable regulations and guidelines as well as to explosion protection measures may be used..



##### **Caution!**

**No caustic, solvent or volatile disinfectants may be used!!**



##### **Danger!**

If you use a disinfectant that can form an explosive gaseous mixture, they must have evaporated before the system is switched on again!!

- All parts of the X-ray equipment, including the accessories and connecting cables may be disinfected by wiping only.
- Spray-disinfections is not recommended because the disinfectant may enter the equipment.
- If you perform room disinfections with an atomizer, you must switch off the X-ray equipment first. When the X-ray equipment has cooled down, cover it carefully with a plastic sheet. When the mist of disinfectant has subsided you can remove the plastic sheets and disinfect the X-ray equipment by wiping.

CS 3000

---

**The following disinfectants can be used:**

- Mild soapy solution
- Misty Multi-Purpose Disinfectant Cleaner - Amrep Inc.
- Misty Multi-Purpose Disinfectant Cleaner II - Amrep Inc.
- Misty Disinfectant and Deodorant RTU - Amrep Inc.
- Virex II 256 - Johnson Professional
- Tego 1103
- Kosolin

## **7 Council Directive 93/42 EEC concerning medical devices, Article 12**

### **Particular Procedure for Systems and Procedure Packs.**

- (1) By way of derogation from Article 11 this Article shall apply to systems and procedure packs.
- (2) Any natural or legal person who puts devices bearing the CE marking together within their intended purpose and within limits of use specified by their manufacturers, in order to place them on the market as a system or procedure pack, shall draw up a declaration by which he states that:
  - a) he has verified the mutual compatibility of the devices in accordance with the manufacturers instructions and has carried out operations in accordance with these instructions:  
and
  - b) he has packaged the system or procedure pack supplied relevant information to users incorporating relevant instructions from the manufacturers:  
and
  - c) the whole activity is subjected to appropriate methods of internal control and inspection.

Where the conditions above are not met, as in cases where the system or procedure pack incorporate devices which do not bear a CE marking or where the chosen combination of devices is not compatible in view of their original intended use, the system or procedure pack shall be treated as a device in its own right and such be subjected to the relevant procedure pursuant to Article 11.

The user is responsible for observance and enforcement of the national deviations in the European Economic Community.

CS 3000

## 8 Name plate location

Labeling:

<b>PAUSCH</b> technologies	
Graf-Zeppelin-Str. 1 D-91065 Erlangen	
Type	<input type="text" value="0128 0001"/>
Fabr. Nr.	<input type="text"/>
Datum	<input type="text"/>
Spanng.	<input type="text" value="115 / 230V"/> Volt DC
Frequenz	<input type="text" value="60 / 50 Hz"/> Hertz
Strom	<input type="text" value="2 / 1 A"/> Ampère
Made in Germany	

CS3TYP02



TYPD0002

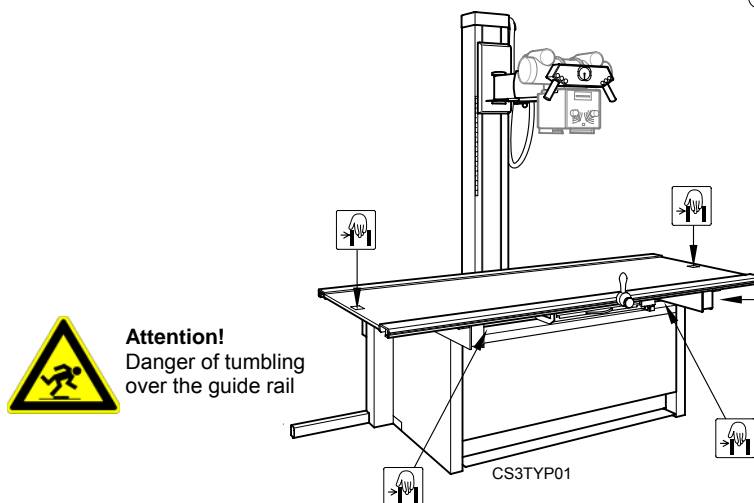

**Attention!**  
Danger of tumbling  
over the guide rail

### 2. CE-Label

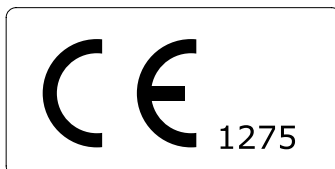

TYPD0002

### 3. UL-Label



TYPE0002

### 5. Typ B



TYPD0003

### 6. Attention! Pinch points

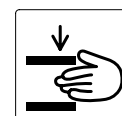

TYPD0004

Specifications are subject to change without notice.