

English Edition

CONTENTS	Page
Important Note	3
Technical Safety Procedure	3
- Regulations	3
Product Safety	4
- Electrical safety	4
- Mechanical safety	4
- Danger of Injury	4
- X-Ray Protection	5
- Explosion Protection	6
- Interference Protection	6
- Classification of product	6
- EC Conformity	6
- Environment Conditions	6
- Waste Disposal	6
Design Features	
- Conception	7
General	
- Brief Description	8
- Range of Application	8
Installation	9
- Floor Space Required	9
- Room Height	9
- AC Power/Mains	9
Operating Elements	10
- Arrangement	10
- Meaning of Symbols/Function	11
Maintenance	12
- Important Note	12
- Operator's Service and Maintenance	12
- Periodic Maintenance	12
- Cleaning	13
- Disinfection	13
- The Council's Directive 93 / 42 EEC on Medical Devices	13
Location of Name Plate	14

Important Note:

To ensure proper operation of this product it is essential that the service personnel is familiar with the "Operating Instructions" which should be studied carefully before use.

Special attention is to be given to the chapter "Safety Notes".

The equipment must be used in accordance with the safety procedures described below and must not be used for purposes other than those for which it was designed. The equipment may only be used by persons having recognised qualification, including adequate training in radiation protection, authorising them to perform the examination or treatment to be carried out.

It is the responsibility of the user to ensure that the government regulations are observed in the operating conditions of the equipment.

Technical Safety Note :

Regulations

If statutory regulations govern the operation of the above equipment, it is the responsibility of the operator to observe them.

For the safety of patients, operators and others, as well as the efficient functioning of the equipment, it is necessary to have periodic service inspections at 12-month intervals according to the maintenance schedule. Please apply to your service organisation for inspection and maintenance.

Inspection intervals must by all means meet the requirements of the respective legislation or government regulations.

Changes and additions to the product must comply with the relevant legislation as well as with the accepted standards of good manufacturing practice.

As manufacturer of electromedical systems, we assume responsibility for the safety of the equipment only if maintenance, repairs and changes are carried out exclusively by us or third parties expressly authorised by us to do so, and if defective parts relating to the safety of the equipment are replaced by genuine spare parts.

We recommend that the service personnel be asked to issue a certificate specifying the kind and extent of the repair carried out, including details on any change of ratings or working ranges. Also, the certificate should show the date of repair, the name of the service company and the signature of the technician.

Before operating the equipment, the operator must check all devices concerning the safe and efficient functioning.

If the user of this equipment likes to combine it with other units, components or assemblies and this can not be made clear from the technical data, he must question us as manufacturer or another expert to make sure that the safety of the patients and operator is covered by the planned combination.

Product Safety

Electrical Safety

Only trained service personnel are permitted to remove covers and panels from the x-ray equipment.

In the Federal Republic of Germany, the electrical installation of rooms used for medical purposes must conform to the provisions of the VDE Standard 0107. In all other countries, the provisions of the applicable local laws and regulations have priority.

Mechanical Safety

It is the responsibility of the operator to ensure the safety of the patient while the unit is in operation by visual check, proper patient positioning, and use of devices that are provided.

Danger of Injury

The solid black arrows and dotted lines in the illustration show areas which present potential Danger of Injury to operating personnel and patient from the equipment motion.

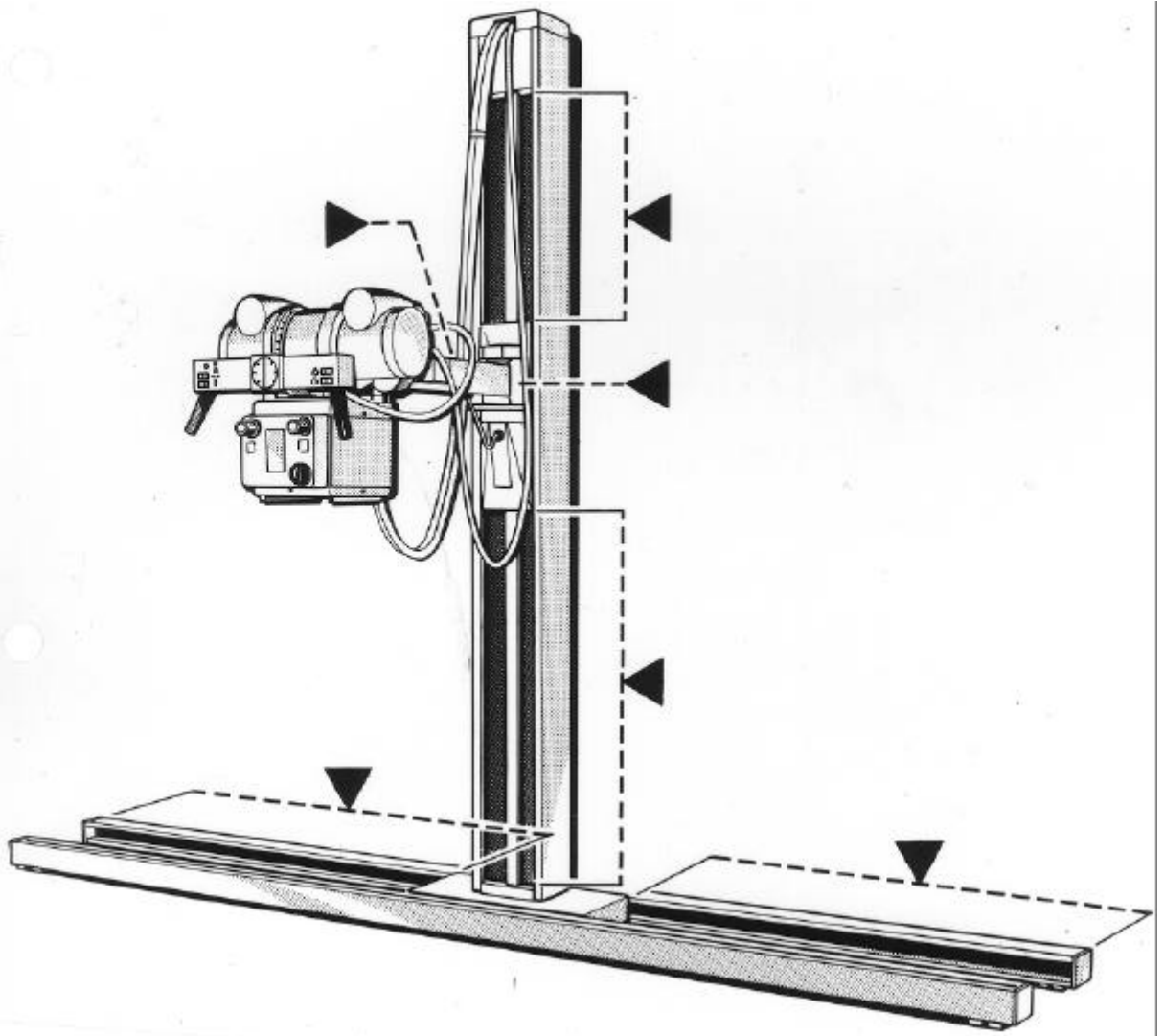

X-Ray Protection

The unit itself has no controls with which radiation could be triggered. Exposure is triggered only from the radiation protected location of the generator. The general radiation-protection measures must be observed. In addition, we recommend the following:

1. Set the tube current as low as possible.
2. Limit the radiation field to the maximum possible extent.
3. Keep as far away as possible.
4. Provide radiation protection for the patient.

Explosion Protection

This equipment is not designed for use in areas where explosion hazard exists. Only cleansing agents which form non-explosive mixtures with air may be used.

Interference Suppression

This equipment is in compliance with EN 60601-1-2. The interference test specifications comply to EN 55011 Class B, Group 1.

Classification of product

The equipment complies to the protection degree of Class I and for protection against electric shock Type B.

EC Conformity

The **RS 85** to which this declaration relates fulfils the general requirements for safety of medical electrical equipment and follows the provisions of Medical Device Directive 93/42 EEC part 11 para. 5 according the procedure in annex VII.

The CE mark is only applicable for the product without X-ray components and Bucky.

The declaration of EC-conformity can be sent to you by request:
Write to:

Hans Pausch
Röntgengerätebau
c/o Quality Assurance Sys. Mgr.

Postfach 28 60

D-91016 Erlangen
Fax #: +49 9131 99 24 22

Environment Conditions

Surrounding temperature range	10° C to 40°
Relative humidity	20% to 80%
Atmospheric pressure	700 hPa to 1100hPa

Waste Disposal:

Legal waste disposal regulations may apply to the disposal of this product. To avoid causing damage to the environment and personal injury, we recommend that you contact your Customer Services representative before permanently removing this product from service.

**Design Features
Conception**

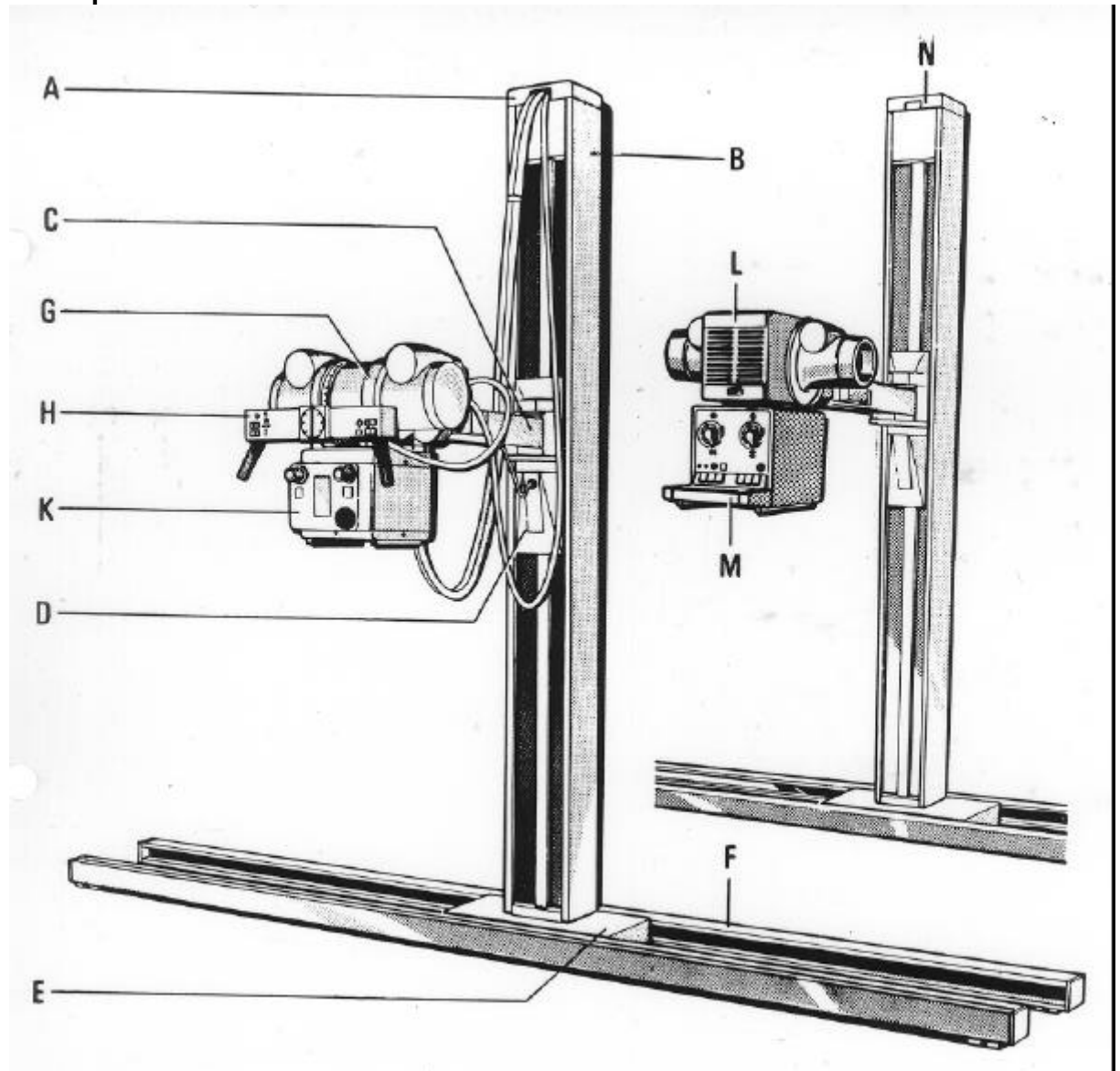

- A top cover
- B column
- C tube support arm
- D vertical carriage
- E column base - movable
- F floor rail
- G x-ray tube
- H controls
- K collimator
- L GE-tube support arm
- M GE-collimator
- N GE-model without control arm

General

- Brief description

The **RS 85** is a free standing tube stand accepting tube-collimator combinations up to 45kg.

The control arm includes push buttons for electromagnetic brakes, the indicator light and protractor.

The tube-collimator combination can be rotated $\pm 180^\circ$ with detent at 0° and $\pm 90^\circ$.

The tube support arm rotates $\pm 90^\circ$ for lateral exposures.

The vertical carriage moves freely without play in the column stand from 185 cm max. down to 41 cm (middle support arm).

The solid column stand is mounted on the column base by means of screws and contains the counterweight.

The travel range of column in the floorrails is: 243 cm.

The top cover contains the electrical interface and serves as cable guide.

The rotational movement, the vertical movement and the longitudinal movement are electromagnetically braked.

Range of Application:

The **RS 85** is a universal tube stand to be used with a Bucky wall stand or a Bucky table in any radiographic room.

Installation

- Floor Space Required

The unit is designed for stationary operation. The floor space required is approx. 130 cm x 310 cm.

- Room Height

The height of the column stand is 226.5 cm. To install the **RS 85**, the room height should be at least 235 cm.

- AC Power (Mains) Connection.

24V DC 1.5 A are required for the electromagnetic brakes and the indicator light beam.

- AC Power (Mains).

The AC power (mains) connection requires a 30mA circuit breaker to be installed in the building. The electrical installation must meet the relevant local legislation, e.g. VDE 0107, IEC/SC 62 A.

Operating Elements - Arrangement

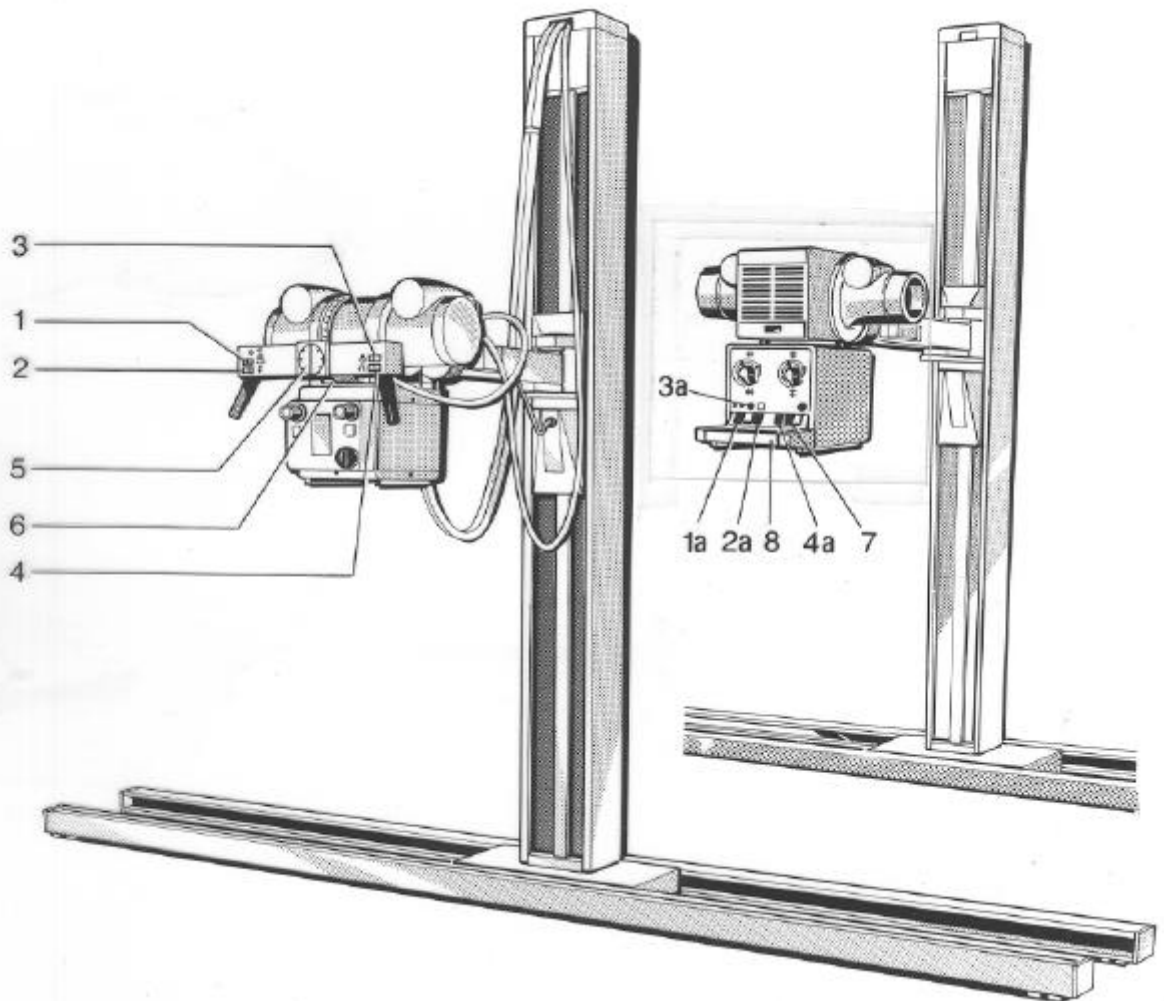

- 1 push button for longitudinal movement of column
- 1a push button for longitudinal movement of column
- 2 push button for vertical movement of tube-collimator assembly
- 2a push button for vertical movement of tube-collimator assembly
- 3 push button for light beam indicator
- 3a push button for field light
- 4 push button for rotational movement of tube-collimator assembly
- 4a push button for rotational movement of tube-collimator assembly
- 5 angle indicator
- 6 field light for Bucky centering
- 7 push button to be used with push button (2a) to stop at 100 cm/40" SID
- 8 control arm

- Meaning of Symbols/Functions

Press and hold button **4** or **4a** to unlock rotational movement brake of the X-ray tube. As soon as push button is released the X-ray tube is locked in its new working position.

Push button **1** or **1a** to unlock longitudinal movement brake of the stand with X-ray tube. As soon as push button is released the X-ray tube is locked in its new working position.

Push button **2** or **2a** to unlock vertical movement brake of the X-ray tube. As soon as push button is released the X-ray tube is locked in its new working position.

Push button **7** in combination with button **2** to get the tube arm support stop automatically at 100cm (40"). Once this SID point is reached the tube is locked in this position. Release button **7** to move away from this position. Push on handle **8** after having pressed any of the functional push buttons (**4a**, **1a**, **2a**) to allow movement.

Goniometer **5** indicates tilting angle of X-ray tube to exposure object.

Optical pointer **6** allows adjustment of the X-ray tube exactly to the middle of the Bucky in longitudinal directions of the table. The optical pointer is activated by pressing push button **3**.

During power failure the brakes of the vertical and longitudinal motion are unlocked.

If an emergency-stop switch is installed in the examination room, the red push button of this emergency-stop switch has to be pressed immediately in case of danger for either patient, operator or the unit. Only if the danger is clearly eliminated the unit may be operated again. To do so the red push button of the emergency-stop switch has to be turned to the right.

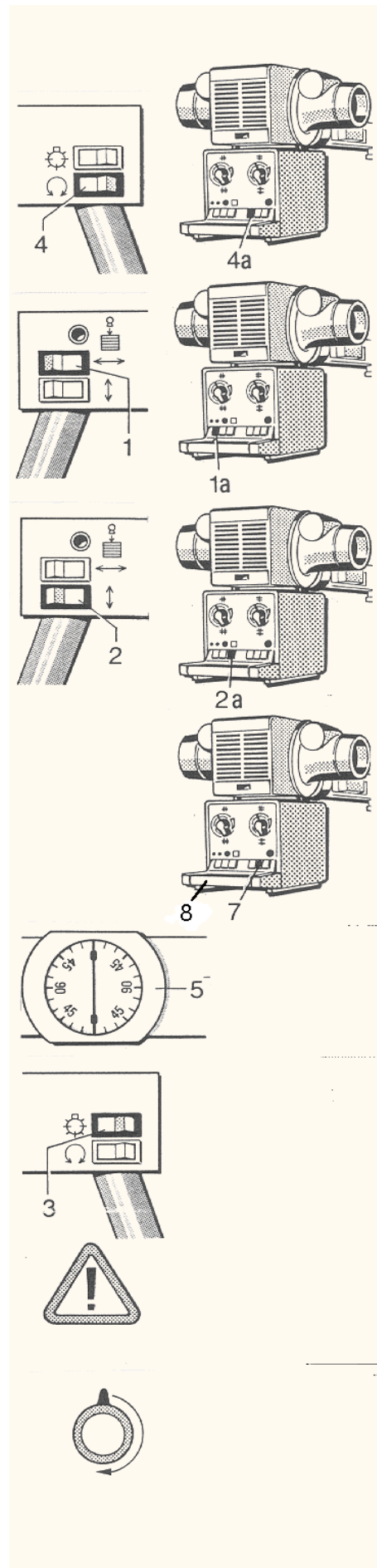

Maintenance:**Important note.**

Like all technical equipment, this unit requires also a regular maintenance service to maintain the safety of the equipment.

Operator's service and maintenance

The operator has to check the x-ray equipment for defects as listed below:

In case of functional defects or other deviations from the normal operation, the equipment has to be switched off at once and the service company has to be informed. The equipment can not be used before all defects have been eliminated.

Daily routine checks

Check Indicator light and operating elements for proper functioning.

Weekly Checks

Check all cables and their connections for traces of wear.

Periodic Maintenance

For trouble-free operation of the **RS 85** as well as safety for patient and user, it is necessary to carry out a technical maintenance by the service company every 12 months.

Please refer to "Technical Maintenance" of the Mounting Instructions.
The steel cable of the column has to be replaced every 3 years.

Attention:

In case of failure of components, which can limit the safety of the equipment, original spare parts have to be used.

We recommend that the service personnel be asked to issue a certificate specifying the kind and extent of work that was done. Also the certificate should show the date of repair, the name of the service company and the signature of the technician.

Cleaning:

The equipment must be switched off before cleaning.

Plastic surface should be cleaned with mild soap only. Do not use strong cleaners or solvents as they will damage the finish or blur the lettering.

At least once a month external parts and exposed tracks on which rollers move should be wiped to remove foreign material which might have accumulated. **DO NOT USE A DAMP CLOTH.** Wipe the tracks with a cloth lightly soaked in with light machine oil or WD-40.

To protect the finish, polish the equipment with PURE liquid paste wax. Do not use wax containing a cleaning substance. Polish all enamelled metal surfaces.

Disinfection:

The equipment has to be switched off before disinfection.

Only disinfection methods can be used that correspond to the relevant regulations and rules as well as the protection from explosion.

Spray disinfection is not recommended because it can get inside of the X-ray equipment.

The Council Directive 93/42/EEC on Medical Devices - Article 12

This document is being revised at the moment by the Council.

However, the Article 12 must be followed by the company or the legal person who put this X-ray unit into operation.

The user is responsible for compliance and implementation of national deviations in the EC

Location of Name Plate

AC Power (Mains) Connection



CE

hp HANS PAUSCH
Röntgengerätebau
D-91056 Erlangen
Graf-Zeppelin-Str. 1

Type
 Fabr.Nr.
 Datum

Spannung Volt
 Frequenz Hertz
 Strom Ampere

Made in Germany

CLASSIFIED
UL

X-RAY EQUIPMENT CLASSIFIED BY
UNDERWRITERS LABORATORIES INC.[®]
WITH RESPECT TO ELECTRICAL FIRE,
SHOCK AND MECHANICAL HAZARDS ONLY.
3E B 7

RS 85



hp HANS PAUSCH
Röntgengerätebau
D-91056 Erlangen
Graf-Zeppelin-Str. 1

Type
 Fabr.Nr.
 Datum

Spannung Volt
 Frequenz Hertz
 Strom Ampere

Made in Germany

CE

CLASSIFIED
UL

X-RAY EQUIPMENT CLASSIFIED BY
UNDERWRITERS LABORATORIES INC.[®]
WITH RESPECT TO ELECTRICAL FIRE,
SHOCK AND MECHANICAL HAZARDS ONLY.
3E B 7

SAFETY

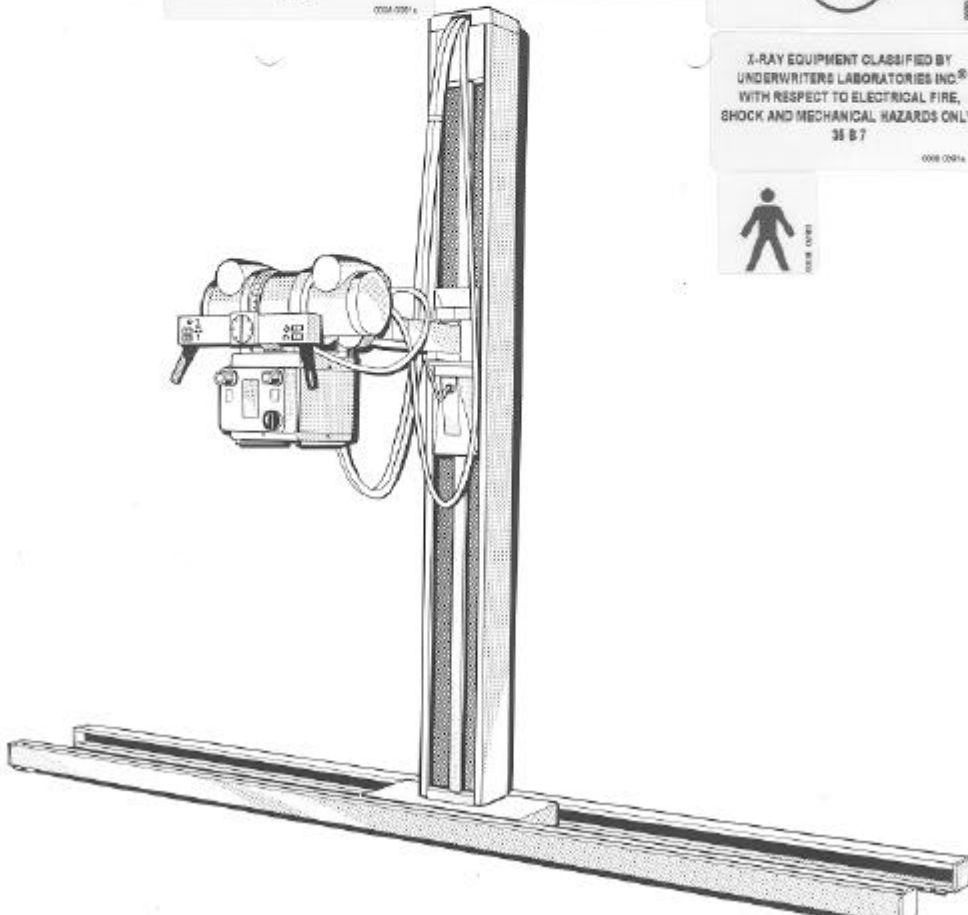

Specifications are subject to change without notice. TV / Ru